



Analysis of Traffic Accidents Caused by Overcome and Left Turn Actions in a Situation When the Vehicles Have Been Moved from the Face of the Place, and There Are no Tracks Found on the Road - A Case Study

Goran Mihaljčić

master of traffic engineer, Banja Luka, BiH, goranmihaljic@hotmail.com

Bojan Mihaljčić

master of traffic engineer, Banja Luka, BiH, bojanmihaljic@hotmail.com

Received: May 31, 2024

Accepted: November 19, 2024

Abstract: The basis for a high-quality analysis of a traffic accident lies in the detailed investigation documentation, which includes precisely defined fixed positions of the vehicle and associated tracks. However, we often face the problem when the participants after the accident move the vehicles from the scene of the event for the smooth flow of traffic, before the competent authorities carry out an investigation or the European accident report is filled out. An additional difficulty arises when there are no visible traces left on the road that could be linked to the place and manner of the accident, which makes it difficult for experts to provide expertise. In such situations, experts must apply non-standard accident analysis methods. Therefore, the goal of this paper is to present, through a practical example of the technical analysis of a real traffic accident, one of the approaches to traffic accident expertise that is characterized by the described problem. The subject of the work are traffic accidents caused by overtaking and left turning, as one of the most common situations in which vehicle collisions occur. The example shows the method of determining the location of a vehicle collision in a transverse sense, the creation of a time-space analysis, and the possibility of avoiding an accident in which the drivers moved the vehicles from the accident site, and no visible traces were left on the roadway.

Keywords: Traffic accident, overtaking, left turn, absence of tracks, analysis.

INTRODUCTION

The analysis of a traffic accident implies the determination, calculation and analysis of material elements that can be obtained from the evidence collected during the investigation of a traffic accident. Such analyzes enable an objective assessment of the factual situation that existed at the time of the traffic accident or that possibly preceded the accident in a short period of time (Marković and Pešić, 2012).

The problem arises when the participants in the accident move their vehicles from the scene before the police officers carry out the investigation of the accident, without even photographing the condition, the positions of the vehicles and any traces of the accident. The reason for these procedures may be ensuring the smooth flow of traffic, filling in the European accident report or simply insufficient knowledge of the participants that such an action can destroy essential traces that are of key importance for the analysis of the accident.

Also, the provision of Article 158 of the Law on Basic Road Safety in Bosnia and Herzegovina, in which it is stated in paragraph 3 that after a traffic accident in which only minor material damage was caused, the participants are encouraged to move the vehicles from the scene. drivers are required to immediately remove vehicles from the roadway and to exchange personal data, and to fill in and sign the European Traffic Accident Report form.

According to the above, it is not a rare situation that an expert in the traffic profession, when preparing the expertise, has the task of performing a time-spatial analysis of the course of the accident, and to declare the possibility of avoiding it, based on documentation that does not contain data on the stopped positions of the vehicle after the collision, nor does it contain data about traces of the accident in the form of traces of braking, drifting or dispersion of fragments from the vehicle. Therefore, the aim of the work is to give guidelines on how to approach

the expert examination of a traffic accident with a characteristic problem, in traffic accidents that occur during overtaking and left turns, and which situation represents one of the most common situations in which traffic accidents occur.

TRAFFIC ACCIDENTS IN OVERTAKING AND LEFT TURN

Overtaking is the passing of a vehicle next to another vehicle moving in the same traffic lane in the same direction (Law on Basic Road Safety in BiH, Article 9). The action of overtaking is one of the most complex actions in traffic, while the action of turning left is one of the most dangerous actions. Expertise of such traffic accidents, i.e. accidents where a collision occurs between an overtaking vehicle and a vehicle making a left turn are specific. Such accidents have some common characteristics, but each accident is also special for itself (Feher and Feher, 2016).

In the analysis of the traffic accident, the characteristic positions of the participants in the traffic accident represent the positions when the participants in the traffic accident could have been observed, when a dangerous situation arose, at what moment the driver reacted to the dangerous situation, when there was a change in the way the vehicle and other participants in the traffic accident were moving, as well as in what position the participants in the traffic accident were at the time of the collision (Vujančić and Ivanišević, 2015). The position of the participant at the time of the collision is the starting point of any time-space analysis, after which the other characteristic positions of the accident participants can be determined.

The location of the collision can be determined based on characteristic changes in the tracks of the vehicle's movement, especially in traffic accidents with pedestrians, if the vehicle was forced to brake at the scene of the accident. At the time of the collision, the vehicles must be located immediately before the places where there are characteristic changes on the tracks of the vehicle's movement (broken track, blackening of the track, interruption of the track, doubling of the track, shearing of the track, scratch marks, etc.). If the investigative documentation did not fix characteristic changes on the tracks of the vehicle's movement, then the place of the collision can be determined approximately based on the position of the fallen characteristic parts or materials that fell from the vehicle (Marković et al., 2014).

In a situation in which, after the collision, the vehicles were moved from the scene of the accident, without their position having been previously fixed, and there are no traces on the roadway caused by the collision of the vehicles, there are no material elements that could be used to determine with certainty the place of primary contact vehicles in the longitudinal sense. However, in

the case of overtaking and left-turning traffic accidents, based only on the analysis of visible damage to the vehicles, it is possible to determine the location of the collision of the vehicle in a transverse sense, and then perform a time-spatial analysis of the accident and an analysis of the possibility of avoiding the accident, which procedure is explained through an example in the continuation of the work.

EXAMPLE OF THE ANALYSIS OF A TRAFFIC ACCIDENT WITH A CHARACTERISTIC PROBLEM

The paper presents an example of the expertise of a traffic accident that occurred while overtaking and turning left, in which the stopping positions of the vehicle after the collision are not known, nor were any traces of the accident found on the spot.

Basic information about the accident

The traffic accident happened on 09.10.2023. year, on the regional road R1 - 2105, in the village of Donja Kola, the city of Banja Luka. The passenger car "Renault Megane" and the passenger car "Nissatn X-Trail" took part in the traffic accident.

In the Record of the investigation, in the column "description of the event", among other things, the following was stated: "The traffic accident occurred when the driver of a passenger car of the brand "Nissan" was traveling on the regional road R1-2105, from the direction of Dobrnja in the direction of Banja Luka, and upon arrival in the immediate vicinity of the "Speed Petrol" gas station, he made a left turn, towards the area of the gas station, during which the left side of the vehicle made contact with the front right part of a "Renault" passenger car, which was moving on the same road in the same direction, and overtook a Nissan passenger car. After the traffic accident occurred, the participants moved the vehicles from the scene of the traffic accident."

In Figure 1a. and 1b. a picture of the scene of the accident from the investigative photo documentation prepared by the PS for BS Banja Luka, as well as a sketch of the scene, was shown.

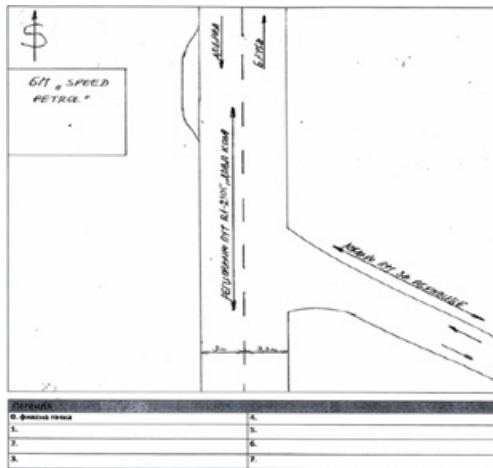

Figure 1. a) Appearance of the scene of the accident from investigative photo documentation b) sketch of the scene of the accident

The rear bumper, rear left side panel, rear left wheel, rear left door, front left door, left sill, front left fender and front bumper were damaged on the passenger car "Nissan X-Trail". The front bumper, front right headlight, front right fender, front right wheel, front right door, rear right door, rear right side panel and rear right wheel were damaged on the passenger car "Renault Megane".

Place of collision and collision position of the vehicle

Since after the accident both vehicles were moved from the scene, and there were no visible traces left on the roadway caused by the collision of the vehicles, there are no material elements on it that could determine the place of primary contact of the vehicles in a longitudinal sense.

In order to bring the vehicles into the collision position and determine the location of the collision in the transverse sense, it is necessary to first determine the collision angle between the longitudinal axes of the collided vehicles and the conflicting surfaces of both vehicles, based on the visible damage from the photo documentation.

The analysis of the damage caused to the vehicles shows that the impact force on the passenger car "Nissan X-Trail" acted diagonally, from the first half of the rear

left door and the left "B" pillar to the front right headlight. On the passenger car "Renault Megane", the collision force acted along the vehicle, from the front right to the rear left corner, over the central part of the front right fender, the right wheel, the front and rear right doors.



Figure 2. a) damage to the passenger car "Nissan X-Trail" b) damage to the passenger car "Renault Megane"

A detailed and comparative analysis of the previously described damage to the vehicles and the direction of impact of the impact force, and bearing in mind their directions of movement immediately before the collision established in the Report of the investigation, it follows that the collision occurred with the front, far right part of the front bumper of the passenger car "Renault Megane" with the left by the side part of the "Nissan X-Trail" passenger car, in the middle of the rear left door and the left "B" pillar. At the time of the collision, the longitudinal axes of the vehicle overlapped each other at an angle of about 20.5°.

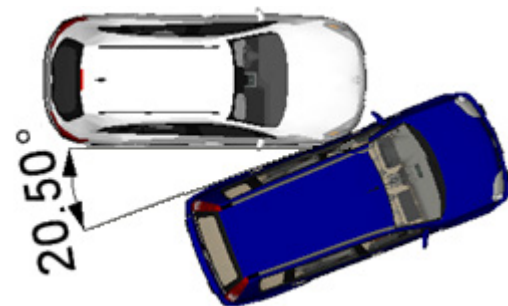

Figure 3. Collision angle between the longitudinal axes of passenger cars "Nissan X-Trail" and "Renault Megane"

Table 1. Determining the turning angle of vehicles through the conflict zone (Society of Engineers and Technicians, Tables for Traffic Technical Expertise, Belgrade, 1991, page 12)

The location of the damage on the overtaking vehicle	The location of the vehicle damage in the left turn	The angle of the vehicle in the left turn [°]
Front right corner	Front left corner	5 – 15
Front right corner	Front left side half	15 – 30
Front right corner	Rear left side half	30 – 40
The front of the vehicle	Back left corner	40 – 60
Front left corner	Back right corner	60 – 65

The angle at which the vehicle turns to the left can also be adopted based on the conflict zones of the vehicle, according to Table 1. In the specific case, the front right corner of the passenger car “Renault Megane” made contact with the front left door of the passenger car “Nissan X-Trail”, and which also corresponds to a deflection angle of about 20 [°].

For a precise analysis and determination of the collision site in the transverse direction, it is also important to know the radius with which the vehicle turned to the left. Since there are no physical traces that would allow determining the path of the vehicle’s movement, and therefore the radius, we will use the median value of the radius that is usually achieved by vehicles when turning left, which is analyzed in the rest of the paper.

In the collection of data related to the radius of the vehicle when turning to the left, we used the results from 25 traffic accident expertises that we conducted in the past period, which occurred during turning and overtaking. Data analysis determined that the median value of the radius at which vehicles turn is 9.2 [m].

Table 2. Realized vehicle radii when turning left

NO	Realized turning radius [m]	NO	Realized turning radius [m]	NO	Realized turning radius [m]
1.	6,5	10.	9,2	19.	6,5
2.	4,3	11.	11,3	20.	15,1
3.	30,4	12.	19,0	21.	16,5
4.	3,6	13.	15,5	22.	6,9
5.	19,5	14.	8,6	23.	4,8
6.	8,2	15.	25,3	24.	32,6
7.	7,6	16.	6,8	25.	10
8.	64,5	17.	23,5		Medijan
9.	8,7	18.	5,5		9,2

Guided by the aforementioned data, on the sketch of the scene drawn to scale, in the simulation software for the analysis of traffic accidents PC Crash 12.1, the passenger car “Nissan X-Trail” was placed in the position in which it was at the time of the collision. This position of the vehicle refers to its transverse position in relation to the longitudinal axis of the roadway.

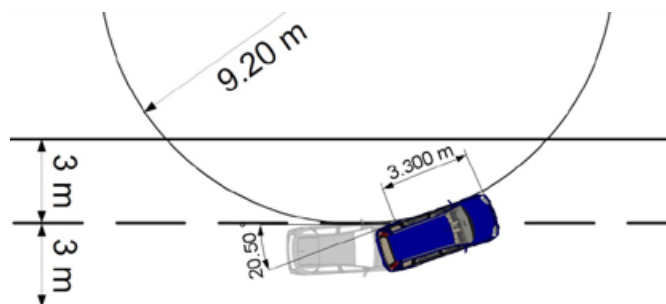

Figure 4. Collision position of passenger car “Nissan X-Trail” in relation to the longitudinal axis of the road

The drawing shows the distance traveled by the vehicle from the point of crossing over the longitudinal dividing line to the collision position, which is 3.3 [m]. As a control of the graphoanalytical method, the path that the vehicle traveled from the violation of the left traffic lane zone to the place of the collision was also obtained by calculation.

$$Sds_{Nissan} = \frac{2 \times r \times \pi}{360} \times \alpha \quad (1)$$

$$Sds_{Nissan} = 3,3 [m]$$

Where is:

Sds_{Nissan} – the path traveled by the passenger car “Nissan X-Trail” from the point of crossing over the longitudinal dividing line up to the collision position [m]

r – turning radius – 9,2 [m]

π – constant – 3,14

α – collision angle between the longitudinal axes of the vehicle 20,5 [°]

After the collision position of the «Nissan X-Trail» passenger car was determined, the «Renault Megane» passenger car was also placed on the sketch of the scene in the simulation software, in the previously defined mutual collision position of the vehicles shown in Figure 3. In this way, the location is obtained vehicle collision in the transverse sense (Figure 5). By reading from the hodogram shown in Figure 5, it follows that the vehicle collision occurred in the transverse sense on the left traffic lane, at about 2.6 [m] away from the left edge of the roadway to the right, viewed in the direction of the vehicle’s movement.

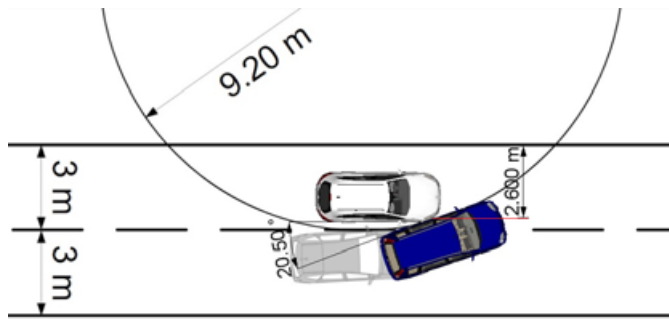

Figure 5. The location of the vehicle collision in a transverse sense

Time-space analysis

Since the location of the vehicle collision is not known longitudinally, there are no elements for calculating the speed of the vehicle at the time of the collision, as well as their speed immediately before the accident.

According to professional literature, the mean value of the speed of a vehicle in a left turn is 19.3 [km/h] with a standard deviation of 6.3 [km/h] (Bogdanović V. et al., 2010), so this speed is adopted as the speed of a Punic car "Nissan X-Trail" at the time of collision, as well as during turning.

At a speed of 19.3 [km/h], the passenger car "Nissan X-Trail" came from the place of crossing over the longitudinal dividing line to the collision position in a time of 0.6 [s].

$$t_{ds \text{ Nissan}} = \frac{S_{ds \text{ Nissan}}}{V_{0 \text{ Nissan}}} \quad (2)$$

$$t_{ds \text{ Nissan}} = 0,6 \text{ [s]}$$

Where is:

$t_{ds \text{ Nissan}}$ – the time elapsed from the occurrence of a dangerous situation until the collision [s]

$S_{ds \text{ Nissan}}$ – the distance traveled by the vehicle from crossing the central dividing line to the collision position – 3,3 [m]

$V_{0 \text{ Nissan}}$ – vehicle speed during the turn – 19,3 [km/h] ili 5,3 [m/s]

The lateral movement performed by the driver of the passenger car "Renault Megane" to move from the right to the left lane in order to perform an overtaking action, on a road width of 6 [m] is about 3 [m]. It took him about 2.8 [s] for this action.

$$t_{tz} = 2,51 \times \sqrt{\frac{dx}{\mu_b \times g}} \quad (3)$$

$$t_{tz} = 2,8 \text{ [s]}$$

Where is:

t_{tz} – dodge time [s]

d_x – lateral shift – 3 [m]

μ_b – lateral adhesion at the point of greatest curvature – 0,25

g – the force of the earth's gravity – 9,81 [m/s²]

From the foregoing, it follows that at the moment when the passenger car «Nissan X-Trail» started crossing the longitudinal dividing line on the left half of the roadway, the passenger car «Renault Megane» was already in the left traffic lane, viewed in the direction of movement, performing an overtaking action.

According to the definition, a dangerous situation is a traffic situation that requires the reaction of at least one participant, in order to avoid an accident (III Yugoslav Conference on Traffic Technical Expertise, Zbornik radova, Belgrade 1989.). Accordingly, the dangerous situation that preceded the accident occurred at the moment when the driver of the passenger car «Nissan X-Trail» started to enter the left half of the road with the front, extreme left corner, on which the passenger car «Renault Megane» was already moving behind him. Such an action required a reaction from the driver of the passenger car «Renault Megane» in order to avoid an accident.

The analysis of the possibility of avoiding a traffic accident requires the choice of temporal or spatial «criterion» by which it will be checked whether the driver had enough time or enough space to stop the vehicle from the moment of creating a dangerous situation to the moment of the collision (Vujančić and Ivanišević, 2015). As there are no elements for calculating the speed of the «Renault Megane» passenger car at the time of the collision, as well as immediately before the accident, there are also no elements to determine how far from the collision site it was at the time of the dangerous situation. Therefore, in this specific case, it is possible to apply the spatial criterion. Considering the known time elapsed from the occurrence of a dangerous situation to the collision, the time criterion was used for the possibility of avoiding the accident.

In our practice, the prevailing driver reaction time is 0.8 [s], which can be increased for situations of greater complexity (Vujančić et al., 2017). The response time of the system and the increase in deceleration for the passenger car are a total of 0.2 [s], so the reaction time of the human-vehicle system is 1 [s].

As the human-vehicle reaction time is 1 [s], and the time in which the passenger car «Nissan X-Trail» traveled from the violation of the left traffic lane zone to the collision position is 0.6 [s], the driver of the passenger car «Renault Megane» under the given conditions did not have time to react to the braking system, and therefore did not have the technical means to avoid an accident.

DISCUSSION

When analyzing and determining the place of collision of vehicles in the transverse sense in the manner presented, due to the lack of material traces, it is necessary to adopt the value of the radius achieved by vehicles when turning to the left. In their Findings, experts often refer to the fact that vehicles turn left on an average radius of

10 [m]. Given that the source of the results of the aforementioned research is not known, for the purposes of the work, an analysis of the turning radius of the vehicle was performed based on the results of 25 traffic accident expertise. It was found that the median turning radius is 9.2 [m].

Using this data, the result was obtained that the "Nissan X-Trail" passenger car traveled a distance of about 3.3 [m] from the violation of the left traffic lane zone to the collision position, see formula (1). If we used the information that vehicles turn left with an average radius of 10 [m], by including this value in formula (1), the result would be that the vehicle traveled a distance of about 3 from the violation of the left traffic lane zone to the collision position, 6 [m]. This difference of 0.3 [m] would also increase the time for which the passenger car "Nissan X-Trail" went from violating the zone of the left traffic lane to the collision position from 0.6 [s] to 0.7 [s], and which further would not significantly affect the result of the time-space analysis. In other words, when determining the location of the collision in the manner presented by the example, the average turning radius of 10 [m] can be used.

The result of the time-space analysis showed that the driver of the passenger car "Renault Megane" started the overtaking action earlier, 2.8 [s], than the driver of the passenger car "Nissan X-Trail" started the left turn, 0.6 [s]. This corresponds to the previously mentioned, that the action of overtaking is far more complex than the action of turning to the left, and therefore its execution takes longer than the turn itself.

CONCLUSION

Overtaking and left-turning traffic accidents are one of the most frequent traffic accidents on the roads, and they also account for a significant share of the number of misdemeanor, criminal and civil proceedings before the courts, as well as a significant share of the number of requests for compensation for material and non-material damage caused by insurance companies. (<https://www.scribd.com/document/585926322/Analiza-Tipicne-Saobracajne-Nezgode-pretnica-i-Lijevo-Skrenia-samir-Gabeljic-i-Nenad-Lukanovic>, 18 March 2024). Therefore, these traffic accidents are often the subject of expert examinations, where the expert is required to perform a time-spatial analysis of the course of the accident, as well as to declare the possibility of avoiding it.

In the absence of material traces in the sense of traces of braking, drifting or dispersion of fragments from the vehicle, it can be very difficult to determine the place of collision and the collision position of the vehicle, which is the starting point of every temporal and spatial analysis of the accident. For this reason, in the paper, through the analysis of a real traffic accident, one of the solutions is given as to how to approach the expertise in

this type of traffic accident with characteristic problems. The example shows the method of determining the place of a vehicle collision in a transverse sense, defining the moment of occurrence of a dangerous situation, making a time-space analysis and analyzing the possibility of avoiding an accident.

It should be borne in mind that the proposed solution has a limitation in the sense that this method of determining the location of a vehicle collision in a transverse sense can only be used in a situation where, based on the statements of the participants or witnesses of the accident, it can be reliably known that the overtaking vehicle entered the collision position the longitudinal axis is approximately parallel to the longitudinal axis of the pavement. If the overtaking vehicle, avoiding the collision, performed an additional maneuver by dodging to the left, the determined location of the collision in the transverse sense in the presented manner will not be correct.

LITERATURE

- [1] Bogdanović, V. and others. (2010). Collision of an overtaking vehicle with a vehicle making a left turn, IX Symposium "Dangerous situation and credibility of the occurrence of a traffic accident", Zlatibor.
- [2] Society of Engineers and Technicians, Tables for Traffic Technical Expertise, p. 12, Belgrade, 1991.
- [3] Feher, L., Feher, S. (2016). Failure of a participant in an accident of two vehicles, one of which was overtaking and the other vehicle was turning left, XV Symposium "Expertise on traffic accidents and insurance fraud", Soko Banja.
- [4] <https://www.scribd.com/document/585926322/Analiza-Tipicne-Saobracajne-Nezgode-pretnica-i-Lijevo-Skrenia-samir-Gabeljic-i-Nenad-Lukanovic>, accessed 18.03.2024. years.
- [5] III Yugoslav Conference on Traffic Technical Expertise, Proceedings, Belgrade 1989.
- [6] Marković, N., Pešić, D. (2012). Dangerous situation and occurrence of a traffic accident, XI Symposium "Analysis of complex traffic accidents and insurance fraud", Zlatibor.
- [7] Marković, N., Smailović, E., Ivanišević, T., Rosić, M. (2014). Determining the place of a collision using the PC Crash software tool and traces fixed by investigative documentation, XIII Symposium "Expertise on traffic accidents and insurance fraud", Divčibare.
- [8] Vujanić, M. and others. (2017). Manual for traffic - technical expertise", Belgrade.
- [9] Vujanić, M., Ivanišević, T. (2015). Temporal-spatial analysis of a traffic accident, journal Vještak, original scientific paper, srt 161-167, Banja Luka, 2015.
- [10] Law on Basic Road Safety in Bosnia and Herzegovina (2023), Official Gazette of Bosnia and Herzegovina No. 46/2023.